

## CPDH3-5V0UB-HF

RoHS Device

Halogen Free

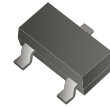

### Features

- Designed to replace polymer TVS.
- Protects up to two I/O lines.
- Ultra-low capacitance (<1pF).
- No insertion loss to > 3.0GHz.
- Low leakage current and clamping voltage.
- Low operating voltage: 5V.
- Solid-state silicon-avalanche technology.
- Transient protection for high-speed data lines to IEC 61000-4-2 (ESD) ±15kV (air), ±8kV (contact) IEC 61000-4-4 (EFT) 40A (5/50ns)

### Mechanical data

- Case: SOT-523 package, molded plastic.
- Epoxy: UL flammability classification rating 94V-0.
- Terminals: Tin plated leads, solderable per MIL-STD-202, method 208.

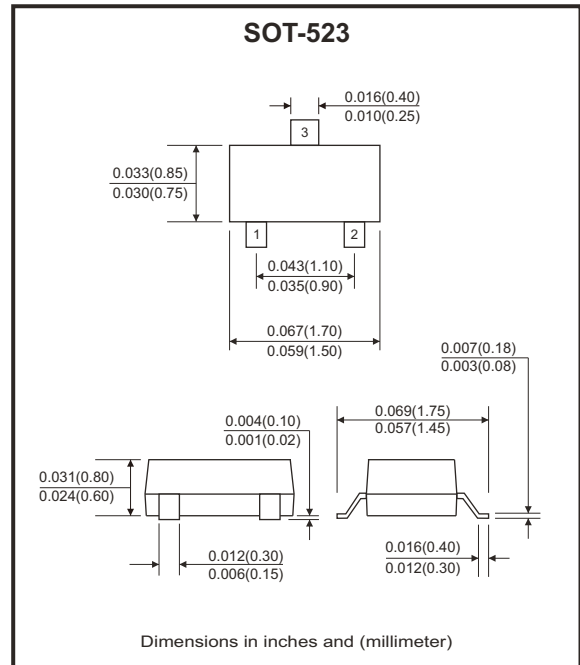

### Circuit Diagram

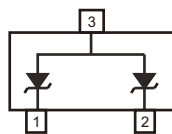

### Maximum Rating (at TA=25°C unless otherwise noted)

Parameter	Symbol	Value	Unit
Electrostatic discharge voltage (IEC 61000-4-2 contact discharge) (IEC 61000-4-2 air discharge)	BV <sub>ESD</sub>	±8 ±15	kV
Peak pulse power dissipation (tp=8/20µs)	P <sub>PP</sub>	125	W
Peak pulse current (tp=8/20µs)	I <sub>PP</sub>	5	A
Junction temperature	T <sub>J</sub>	125	°C
Storage and operating temperature range	T <sub>STG</sub> , T <sub>amb</sub>	-55 ~ +150	°C

## Electrical Characteristics (at TA=25°C unless otherwise noted)

Parameter	Conditions	Symbol	Min	Typ	Max	Unit
Reverse stand-off voltage	Pin 1 or Pin 2 to Pin 3 and between Pins 1 and 2	$V_{RWM}$			5	V
Reverse breakdown voltage	$I_R = 1\text{mA}$ Pin 1 or Pin 2 to Pin 3 and between Pins 1 and 2	$V_{BR}$	6			V
Reverse leakage current	$V_{RWM} = 5\text{V}$ Pin 1 or Pin 2 to Pin 3 and between Pins 1 and 2	$I_R$			1	$\mu\text{A}$
Clamping voltage	$I_{PP} = 1\text{A}$ , $t_p = 8/20\mu\text{s}$   Pin 1 to Pin 2	$V_C$			15	V
	$I_{PP} = 5\text{A}$ , $t_p = 8/20\mu\text{s}$   Pin 1 or Pin 2 to Pin 3				22	
	$I_{PP} = 5\text{A}$ , $t_p = 8/20\mu\text{s}$   Pin 1 to Pin 2				25	
Diode capacitance	$V_R = 0\text{V}$ , $f = 1\text{MHz}$	$C_J$		0.6	0.9	pF

## Rating and Characteristic Curves (CPDH3-5V0UB-HF)

Fig.1 - 8/20 $\mu\text{s}$  Peak Pulse Current Waveform Acc. IEC 61000-4-5

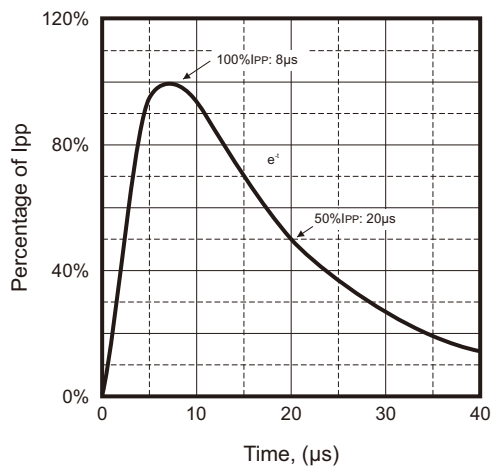
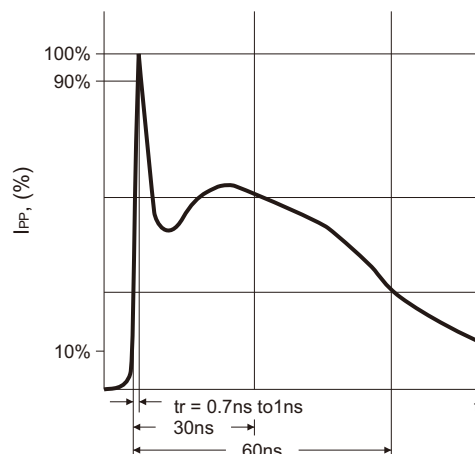
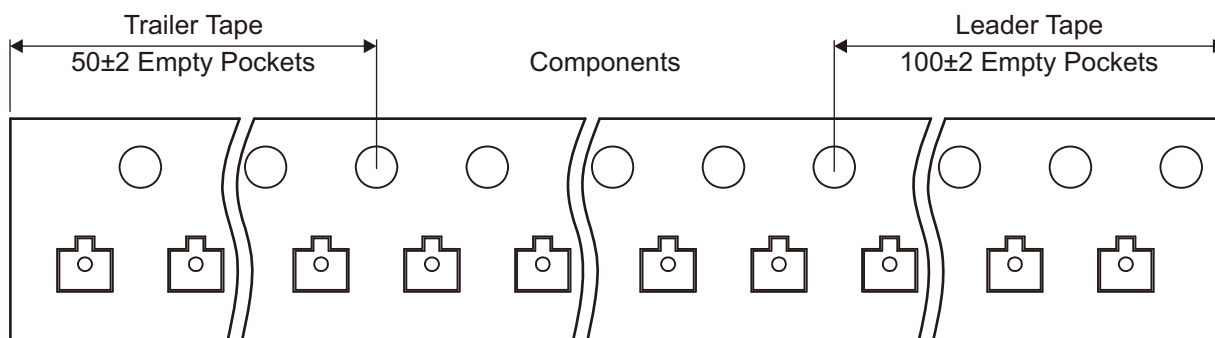
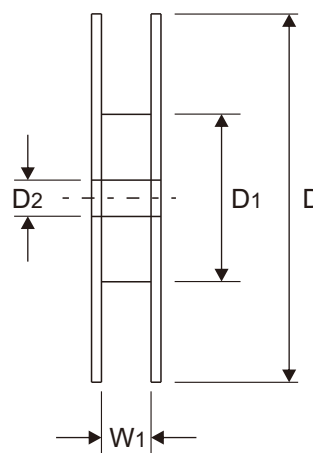
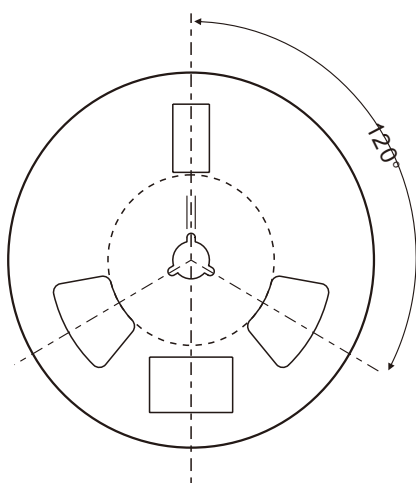
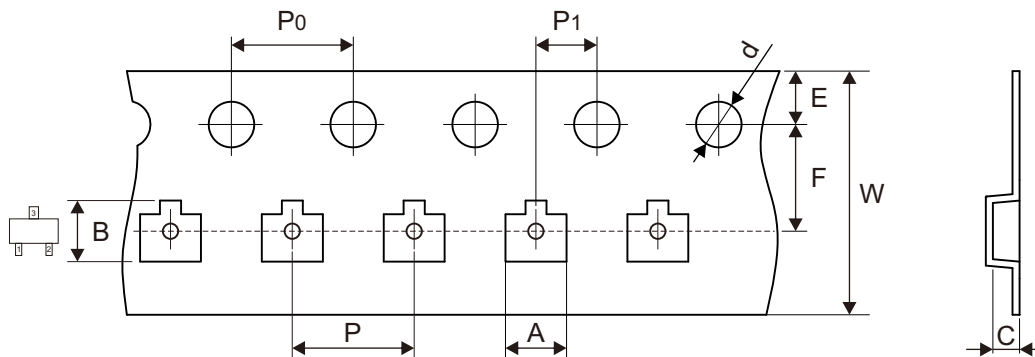

Fig.2 - ESD Pulse Waveform According to IEC 61000-4-2



## Reel Taping Specification



SOT-523	SYMBOL	A	B	C	d	D	D1	D2
	(mm)	1.85 ± 0.05	1.85 ± 0.05	0.875 ± 0.05	1.50 ± 0.10	178.00 ± 1.00	54.00 ± 0.50	13.00 ± 0.50
	(inch)	0.073 ± 0.002	0.073 ± 0.002	0.034 ± 0.002	0.059 ± 0.004	7.008 ± 0.039	2.126 ± 0.020	0.512 ± 0.020

SOT-523	SYMBOL	E	F	P	P0	P1	W	W1
	(mm)	1.75 ± 0.10	3.50 ± 0.05	4.00 ± 0.10	4.00 ± 0.10	2.00 ± 0.05	8.00 + 0.20 - 0.10	9.50 ± 1.00
	(inch)	0.069 ± 0.004	0.138 ± 0.002	0.157 ± 0.004	0.157 ± 0.004	0.079 ± 0.002	0.315 + 0.008 - 0.004	0.374 ± 0.039

Company reserves the right to improve product design, functions and reliability without notice.

REV:A

## Marking Code

Part Number	Marking Code
CPDH3-5V0UB-HF	P5

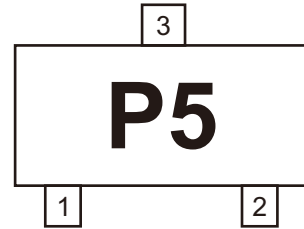

## Suggested PAD Layout

SIZE	SOT-523	
	(mm)	(inch)
A	0.356	0.014
B	0.508	0.020
C	1.00	0.039
D	0.787	0.031
E	1.803	0.071

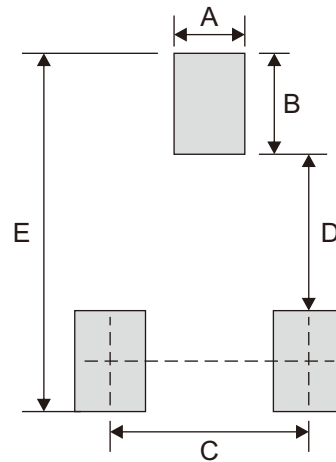

## Standard Packaging

Case Type	REEL PACK	
	REEL (pcs)	Reel Size (inch)
SOT-523	3,000	7